

AMS E-GEAR[®]

MODELS 3000 / 4000 / 5000 / 6000 / 7000 / 9000

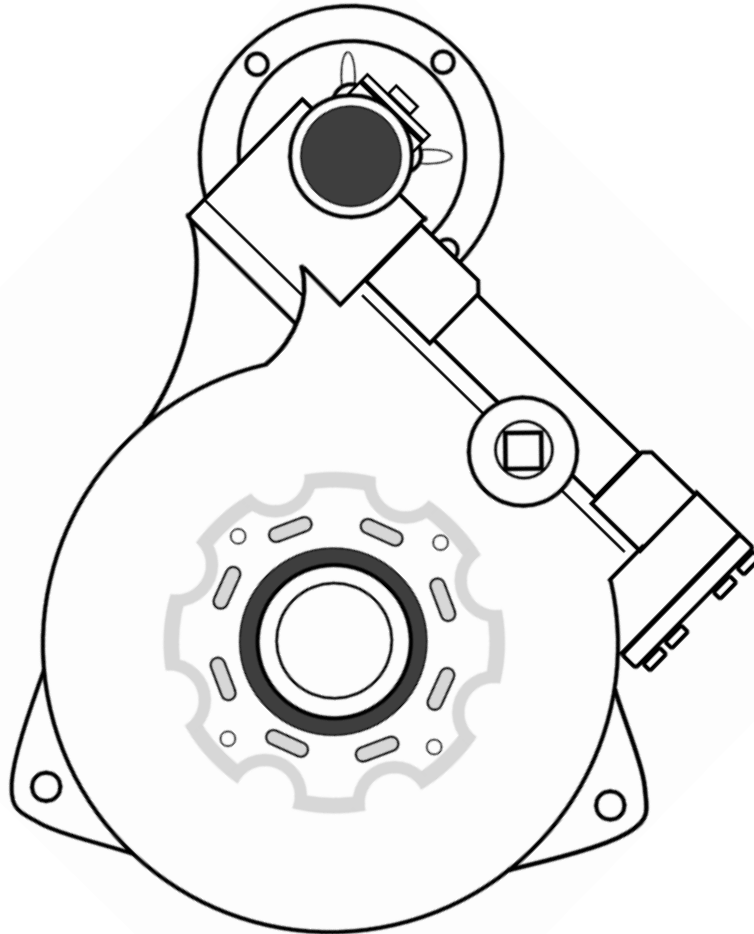





Copyright® 2024 by Aqua Marine Supply/Hefty Hoist, Inc.
No portion of this manual or any artwork contained herein may be reproduced in any shape or form without the express written consent of Aqua Marine Supply/Hefty Hoist, Inc. Diagrams within this manual may not be drawn proportionally and/or be oversimplified for demonstration purposes. Due to continuing improvements, actual product may differ slightly from the product described herein.

▲WARNING

Read this material before using this product. Failure to do so can result in serious injury. SAVE THIS MANUAL

Table of Contents

Safety	2	Specifications	6
Overview	3	Installing Covers	7
Technical Information.....	4	Max Load & Speed Chart	8-9
Installation Information.....	4-5	Warranty	10
Mounting the Electric Motor	5	Troubleshooting.....	11-12
Operating the E-Gear.....	6		

WARNING SYMBOLS AND DEFINITIONS	
	This is the safety alert symbol. It is used to alert you to potential personal injury hazards. Obey all safety messages that follow this symbol to avoid injury or death
	Indicates a hazardous situation which, if not avoided, will result in death or serious injury
	Indicates a hazardous situation which, if not avoided, Could result in death or serious injury
	Indicates a hazardous situation which, if not avoided, Could result in minor or moderate injury
	Addresses practices not related to personal injury

IMPORTANT SAFETY INFORMATION

DANGER

TO PREVENT SERIOUS INJURY AND DEATH:

Basic Safety Information

- Do not lift people or lift loads near people.**
Falling loads can injure or kill people.
Do not use as elevator for human use.
- Do not operate the hoist when load is not centered in lift**
- Do not operate hoist with kinked or damaged lift cables**
Inspect lift cables before every use
- Do not operate hoist if damaged or malfunctioned in any way**
- If servicing or replacing parts, ensure the load is removed and cables are slack**
- Lift should be installed in a location that allows the operator to move and stay clear of the load
- Keep clear of moving parts during operation
- Electrical equipment should only be installed and maintained by a qualified electrician

Overview & Features

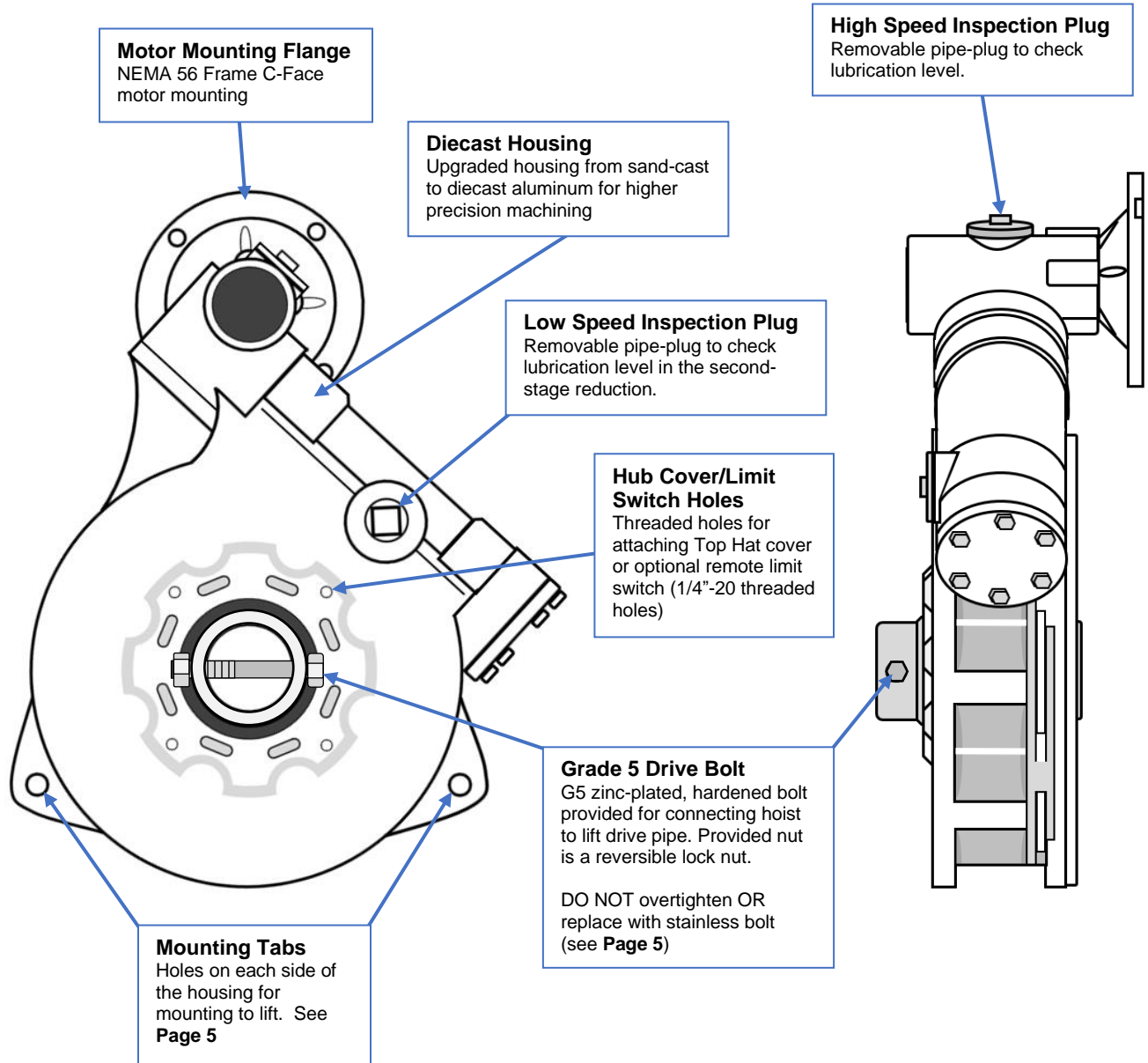

General Description

The AMS E-Gear® is an electric-powered, fully enclosed mechanical gear-driven hoist intended for use primarily in boat lifts, but also cargo lifts and other specialized applications. The gearing is intentionally designed to be inefficient to hold the rated load without the need for other equipment such as a brake motor. Under normal usage, operating conditions, and proper maintenance, AMS E-Gear® hoists can last for decades on lifts.

Mounting Dimensions

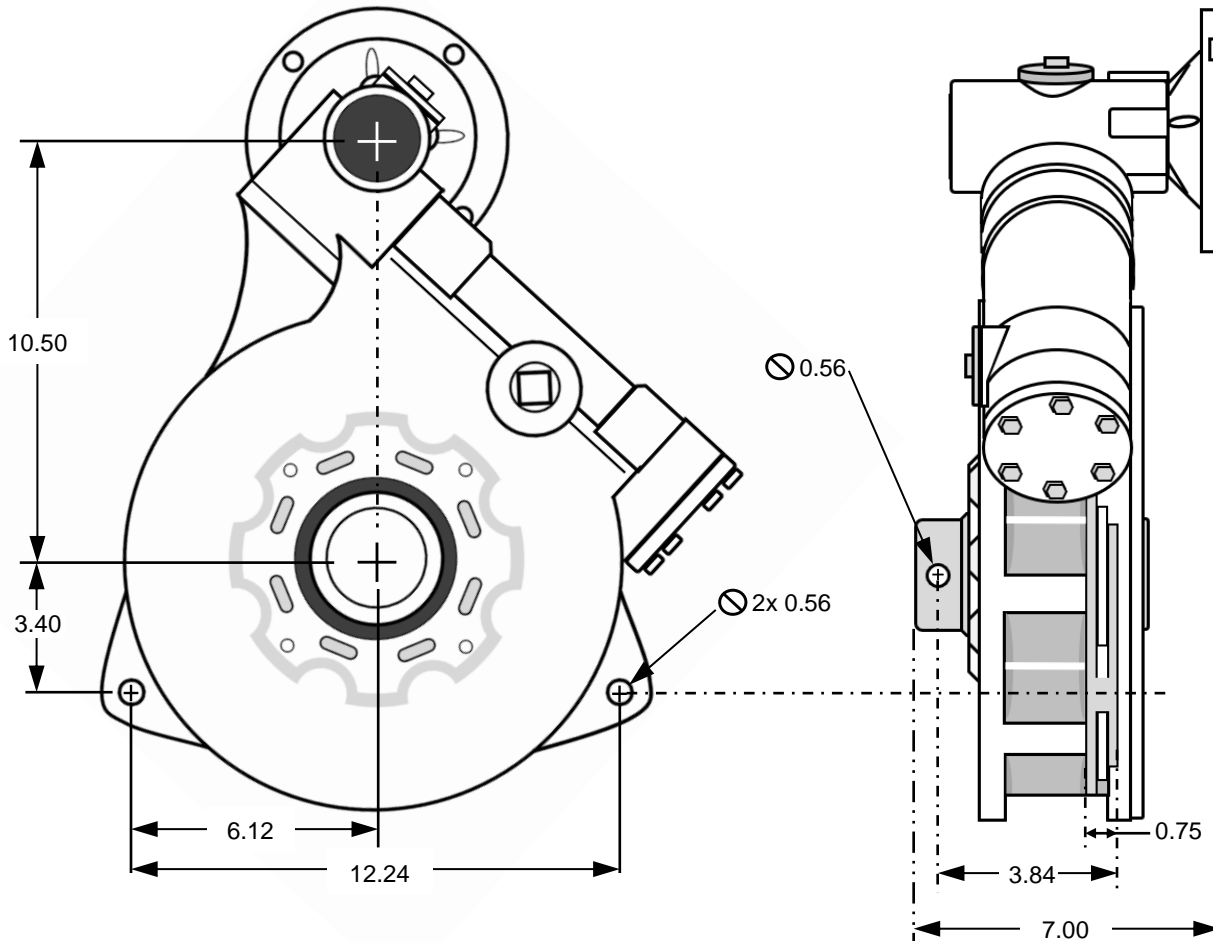

Technical Information

MODELS

The AMS Enclosed Gear or E-Gear® is available in multiple configurations of gear ratios and motor sizes creating a range of models from the EG-3000 up to the EG-9000. All models use the same gearbox housing with identical mounting dimensions.

Considering Aqua Marine Supply/Hefty Hoist does not create the entire lift, these model numbers DO NOT refer to the weight capacity of the hoist, but rather the maximum amount of torque (in inch-pounds) that they output. The diameter of the winding drum/pipe and the rigging of the lift cables (not supplied by AMS) will greatly affect the speed and weight capacity of a hoist. The lift manufacturer who utilizes our hoist and sells the lift as a package is the only party that can determine the final weight capacity.

Standard E-Gear® Configurations

Model	Gear Ratio	Motor HP	Motor Finish	Voltage
3000	480:1	3/4	Painted (Stainless optional)	115/230
4000	480:1	1	Painted (Stainless optional)	115/230
5000	480:1	1 HD	Painted (Stainless optional)	115/230
6000	480:1	1-1/2	Painted (Stainless optional)	115/230
7000	600:1	1-1/2	Painted (Stainless optional)	115/230*
9000	600:1	2	Stainless Standard	115/230*

*230V recommended due to amp draw of motor

SPEED & TORQUE

Speed and torque are an inverse relationship, and anything done to speed the hoist up will decrease its output torque. The standard E-Gear® models are designed to operate with a 1725 RPM motor; however a 3450 RPM motor is available for use with the 600:1 ratio model but the output torque will be reduced by 50%.

Installation Information

NOTICE

CAUTION

Alignment: It is important that the AMS E-Gear® be mounted so that the winding pipe is concentric and in line with the opening in the through-hole in the output shaft. Misalignment at this point can cause binding, wear, and noise and will void the warranty.

Bearing Placement: It is important that the drive shaft or winding pipe being used on the lift be supported properly with bearings. AMS drives are made to turn the pipe and are not to be load-bearing. Therefore, it is important that a support bearing be installed as close as possible to the E-Gear®.

Orientation: The E-Gear® should only be mounted vertically with the motor at the highest point (12 o'clock) for proper internal lubrication (**Figure 5a** below). If necessary for clearance, the drive can be rotated up to 30 degrees in either direction. Mounting the E-Gear® with the motor lower than this point will void the warranty.

Figure 5a

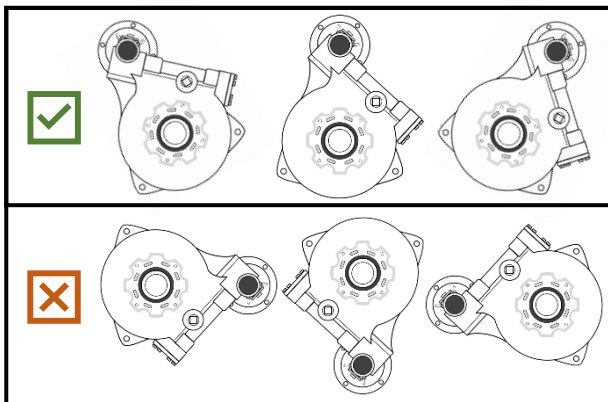

Mounting: The E-Gear® should be fastened to the lift piling, beam, or structural joist to prevent the hoist from rotating under operation. It is common in shaft-mounted gearboxes to utilize a torque link to accomplish this. The ideal position of the torque link would be exactly tangent to the round part of the housing as shown in **Figure 5b** below. As shown in the figure, this tangent line can deviate up to 30° if necessary. Torque links installed further from tangency could cause the mounting tab to break off from the housing.

Figure 5b

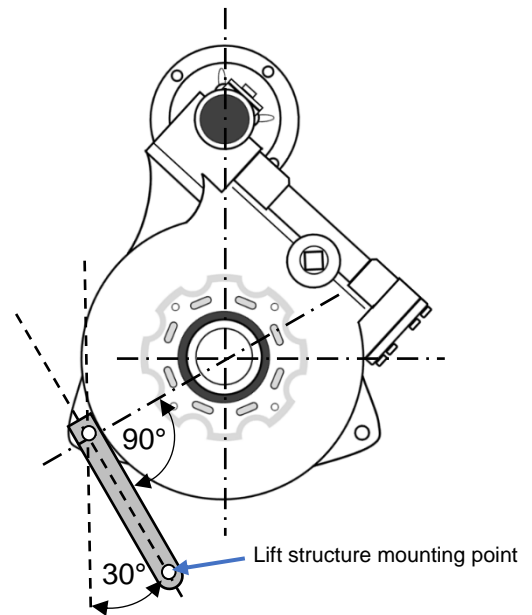

Drive Bolt & Nut: The provided drive bolt is a grade 5, zinc-plated, casehardened 1/2 inch bolt with yield and breaking strength far superior to the maximum load rating of the E-Gear®. DO NOT replace this bolt with a stainless steel bolt for any reason. The provided nut is a reversible lock nut which can be installed in either direction and will lock in position similar to a nylon lock nut. This nut should NOT be tightened all the way against the gear sleeve as pressure against it could fracture the sleeve. The nut is only good for one use and should be replaced if needed to be removed for any reason.

Winding/Drive Pipe: The AMS E-Gear® is designed to mount to a 2 inch pipe (2.375 inch outside diameter). If a 1-1/2 inch pipe is being used, then a spacer or adapter must be added (not provided by AMS) to take up the empty space.

⚠WARNING

Failure to fill this empty space with a spacer can cause the provided drive bolt to bend or fail which could lead to catastrophic failure.

Mounting the Electric Motor

⚠ WARNING

TO PREVENT SERIOUS INJURY, ENSURE THE ELECTRICAL CIRCUIT IS SWITCHED OFF BEFORE PROCEEDING

1. Install the 3/16 key into the keyway on the motor shaft.
2. Lubricate the shaft of the motor with the ant-seize packet provided in the E-Gear® hardware package.
3. Insert the motor shaft into the input shaft of the E-Gear®. Be sure to align the key with the keyway in the input shaft bore.
4. The motor should slide all the way into the input shaft without much force. The motor key may have moved out of position if excessive force required. Remove the motor, reinstall the key and try again.
5. Once the motor is fully inserted, rotate the motor to line up the four mounting holes with the holes in the E-Gear® flange. Make sure the capacitor of the Electric Motor is at the highest point.
6. Secure the Electric Motor to the mounting flange with the provided hardware; stainless steel 3/8-16 x 1" bolts and split lock-washers
7. If the Electric motor has removable weep hole plugs for condensation. Remove the plug(s) at the lowest point to avoid water building up inside.

Electric Motor Connections

The provided electric motor from Aqua Marine Supply/Hefty Hoist, Inc® is a 115/230V, single phase, reversible motor that should only be installed by a qualified electrician. The electrical circuit should be GFCI protected and should contain the proper size wiring to ensure full voltage to the motor on the hoist. Failure to supply the correct and full electrical voltage to the motor or failing to make the proper connections will permanently damage the motor and is not covered by warranty.

For electric motors that were not wired to controls from factory, wiring schematics can be found at www.HeftyHoist.com/wiring-diagrams. Please do not contact us with questions about compatibility with non-AMS equipment as we will not be able to assist.

Before Operating Hoist

1. Familiarize yourself with all operating controls of the hoist and with the operation(s) of the manufacturer's lift. Also familiarize yourself with the instructions, including the warning(s) on the hoist and lift and with the safety information within this manual. Read all information provided by the lift manufacturer regarding your specific lift.
2. **TO PREVENT SERIOUS INJURY FROM LIFT FAILURE:**
Do not use damaged equipment. If repairs are necessary or any defect known, have the issues corrected before use.
3. Inspect the Hoist and other lift components thoroughly before use.

Operating the E-Gear®

For AMS Reversing Switch installations:

Rotate the switch handle to the desired lifting direction (UP or DOWN). See Figure 6

NOTE: A **Momentary** style switch will require the user to hold the handle in the desired operating position and if released, the handle should return to the OFF position automatically. A **Maintaining** style switch will allow the switch handle to maintain the position selected throughout operation and the handle needs to be rotated back by the user to the OFF position when finished.

For Remote Control installations:

Follow directions provided by the Remote Control manufacturer for proper operation.

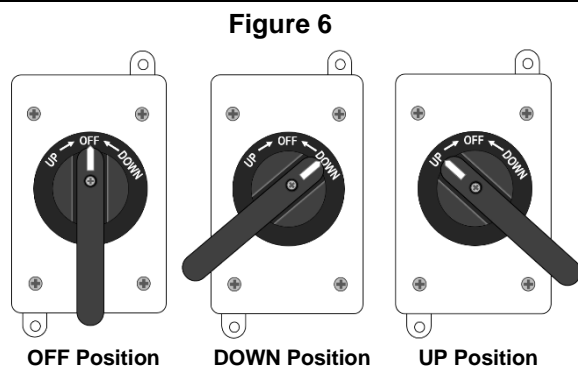

Maintenance Information

The output shaft of the AMS E-Gear® is the hub of the bull gear and is a machined, bare-steel surface that can corrode. This surface is factory-protected with an anti-corrosive compound that will dissipate over time. It is recommended that this surface be continually protected during service on both the front and back side. Failure to protect this surface from corrosion could cause seal damage and could result in a leak of the internal lubricant. The provided Top Hat cover also helps assist with corrosion protection.

The design of the AMS E-Gear® eliminates the need for periodically lubricating grease fittings such that you would find on exposed gear hoists. However, it is still recommended that the E-Gear® be inspected by a qualified technician at least once per season to maintain warranty. A record of such inspection may be required if warranty is attempted to be claimed by the user.

Lubricant Type

The AMS E-Gear® is factory-filled with **Mobilux EP 023** semi-fluid grease which is a specially formulated lubricant for enclosed gearboxes.

Specifications

Model	3000	4000	5000	6000	7000	9000
Torque Rating	3,000 in-lb	4,000 in-lb	5,000 in-lb	6,000 in-lb	7,000 in-lb	9,000 in-lb
Gear Ratio	480:1				600:1	
Motor HP	3/4	1	1 HD	1-1/2	1-1/2	2
Motor Amps (115/230)	12.2 / 6.1	12.2 / 6.1	13.6 / 6.8	22.0 / 11.0	22.0 / 11.0	18.0 / 9.0
Rated Motor RPM	1725					
Standard Output RPM	3.59			2.88		
Lubricant Type	Mobilux EP 023					
Lubricant Capacity	7.2 FL OZ (High Speed Chamber) / 53.6 FL OZ (Low Speed Chamber)					
Straight-pull maximum load (2.375 OD pipe) see Page 9	2,526 lb	3,368 lb	4,211 lb	5,053 lb	5,895 lb	7,579 lb

E-Gear Covers Installation

E-Gear Top Hat Cover (AMS P/N 11210)

The Top Hat cover is provided to help protect the steel gear hub from corroding. Once the E-Gear is mounted to the lift and the drive bolt is installed, the black Top Hat cover can be installed.

1. Use the provided 1/4-20 x 1/2 inch stainless steel bolts to attach the cover as shown to the right.

Note: this cover will not be able to be used if the E-Gear is mounted mid-pipe or if a limit switch has been installed at this location already

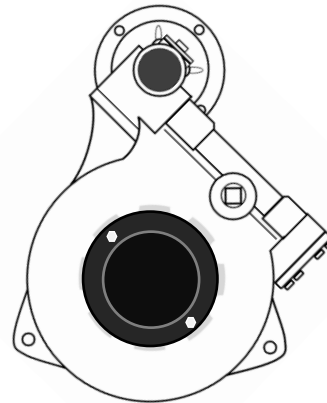

C-Face Motor Cover (AMS P/N 11200)

1. Remove the two lower motor mounting bolts and lock washers. The upper bolts will keep the motor in position temporarily.
2. Position the lower portion of the cover under the Electric Motor and E-Gear mounting flange (lower cover has tabs on the end and holes drilled in the surface for drainage)

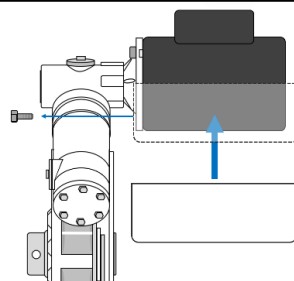

3. Reinstall the bolts and washers removed in step one to secure the lower portion of the cover
4. Route the electrical cord from the Electric Motor through the slot in the lower cover
5. Remove the two higher motor mounting bolts and lock washers
6. Position the upper portion of the cover making sure the tabs on the lower portion enter the slots on the upper portion
7. Once the two portions of the cover are together, reinstall the two bolts and lock washers removed in Step 5

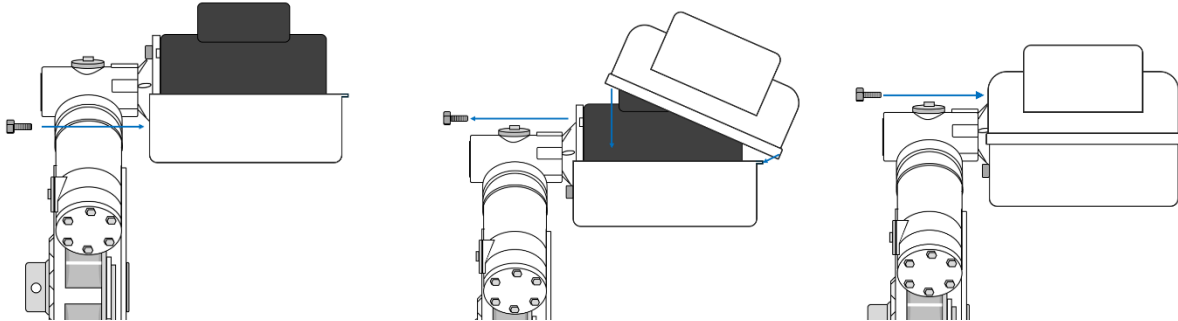

Max Load & Lift Speed Chart

The chart on the following page can be used to determine the maximum load a particular model E-Gear® can lift based on the winding pipe and cable configuration. The chart only accommodates for lifts with one E-Gear®; if multiple gear drives are used on the same lift, then multiply the Max Load value in the chart by the number of E-Gear® drives on the lift.

* "Winding Pipe" refers to the surface where the cable actually winds up. If a sleeve, winder, or spool is used over the nominal drive pipe, use the OD of that item and see corresponding line in chart (see **Figure 8a**). The chart assumes neatly wrapped lift cable and does not accommodate for overlap which will affect speed and max load.

** See **figure 8b** for Cable Compounding information

Figure 8a

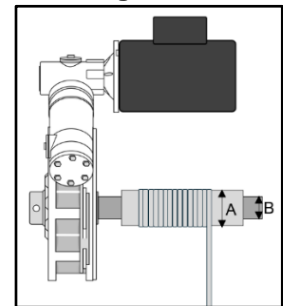

In the above example, dimension "A" would be used as the winding pipe value in the load chart, not "B"

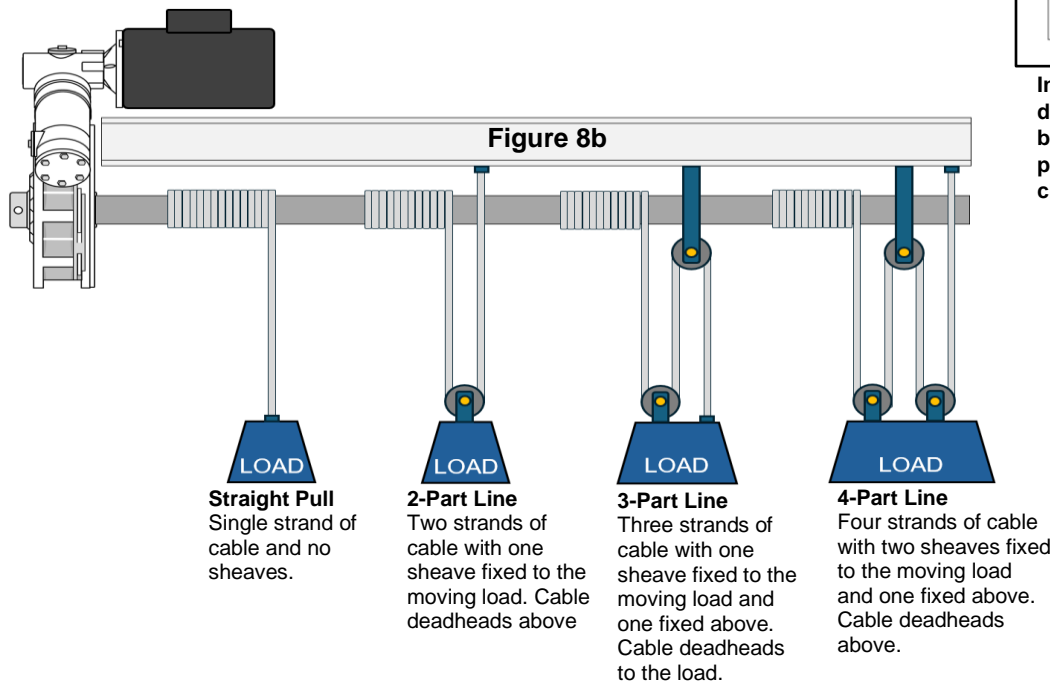

		3000 E-Gear		4000 E-Gear		5000 E-Gear		6000 E-Gear		7000 E-Gear		9000 E-Gear	
Winding Pipe	Lift Cable Compounding	Max Load per Hoist (Lb)	Vertical Speed (in/min)	Max Load per Hoist (Lb)	Vertical Speed (in/min)	Max Load per Hoist (Lb)	Vertical Speed (in/min)	Max Load per Hoist (Lb)	Vertical Speed (in/min)	Max Load per Hoist (Lb)	Vertical Speed (in/min)	Max Load per Hoist (Lb)	Vertical Speed (in/min)
1.5" Pipe (1.9" OD)	Straight Pull	3,000	21.5	4,000	21.5	5,000	21.5	6,000	21.5	7,000	17.2	9,000	17.2
	2 Part Line	5,684	10.7	7,579	10.7	9,474	10.7	11,368	10.7	13,263	8.6	17,053	8.6
	3 Part Line	8,053	7.2	10,737	7.2	13,421	7.2	16,105	7.2	18,789	5.7	24,158	5.7
	4 Part Line	10,105	5.4	13,474	5.4	16,842	5.4	20,211	5.4	23,579	4.3	30,316	4.3
2" Pipe (2.38" OD)	Straight Pull	2,526	26.8	3,368	26.8	4,211	26.8	5,053	26.8	5,895	21.5	7,579	21.5
	2 Part Line	4,547	13.4	6,063	13.4	7,579	13.4	9,095	13.4	10,611	10.7	13,642	10.7
	3 Part Line	6,442	8.9	8,589	8.9	10,737	8.9	12,884	8.9	15,032	7.2	19,326	7.2
	4 Part Line	8,084	6.7	10,779	6.7	13,474	6.7	16,168	6.7	18,863	5.4	24,253	5.4
2.5" Pipe (2.88" OD)	Straight Pull	2,087	32.5	2,783	32.5	3,478	32.5	4,174	32.5	4,870	26.0	6,261	26.0
	2 Part Line	3,757	16.2	5,009	16.2	6,261	16.2	7,513	16.2	8,765	13.0	11,270	13.0
	3 Part Line	5,322	10.8	7,096	10.8	8,870	10.8	10,643	10.8	12,417	8.7	15,965	8.7
	4 Part Line	6,678	8.1	8,904	8.1	11,130	8.1	13,357	8.1	15,583	6.5	20,035	6.5
3" Pipe (3.5" OD)	Straight Pull	1,714	39.5	2,286	39.5	2,857	39.5	3,429	39.5	4,000	31.6	5,143	31.6
	2 Part Line	3,086	19.8	4,114	19.8	5,143	19.8	6,171	19.8	7,200	15.8	9,257	15.8
	3 Part Line	4,371	13.2	5,829	13.2	7,286	13.2	8,743	13.2	10,200	10.5	13,114	10.5
	4 Part Line	5,486	9.9	7,314	9.9	9,143	9.9	10,971	9.9	12,800	7.9	16,457	7.9
3.5" Pipe (4" OD)	Straight Pull	1,500	45.2	2,000	45.2	2,500	45.2	3,000	45.2	3,500	36.1	4,500	36.1
	2 Part Line	2,700	22.6	3,600	22.6	4,500	22.6	5,400	22.6	6,300	18.1	8,100	18.1
	3 Part Line	3,825	15.1	5,100	15.1	6,375	15.1	7,650	15.1	8,925	12.0	11,475	12.0
	4 Part Line	4,800	11.3	6,400	11.3	8,000	11.3	9,600	11.3	11,200	9.0	14,400	9.0
4" Pipe (4.5" OD)	Straight Pull	1,333	50.8	1,778	50.8	2,222	50.8	2,667	50.8	3,111	40.6	4,000	40.6
	2 Part Line	2,400	25.4	3,200	25.4	4,000	25.4	4,800	25.4	5,600	20.3	7,200	20.3
	3 Part Line	3,400	16.9	4,533	16.9	5,667	16.9	6,800	16.9	7,933	13.5	10,200	13.5
	4 Part Line	4,267	12.7	5,689	12.7	7,111	12.7	8,533	12.7	9,956	10.2	12,800	10.2
5" Pipe (5.56" OD)	Straight Pull	1,079	62.8	1,438	62.8	1,798	62.8	2,157	62.8	2,517	50.2	3,236	50.2
	2 Part Line	1,941	31.4	2,589	31.4	3,236	31.4	3,883	31.4	4,530	25.1	5,824	25.1
	3 Part Line	2,750	20.9	3,667	20.9	4,584	20.9	5,501	20.9	6,417	16.7	8,251	16.7
	4 Part Line	3,451	15.7	4,602	15.7	5,752	15.7	6,903	15.7	8,053	12.6	10,354	12.6
6" Pipe (6.63" OD)	Straight Pull	906	74.8	1,208	74.8	1,509	74.8	1,811	74.8	2,113	59.8	2,717	59.8
	2 Part Line	1,630	37.4	2,174	37.4	2,717	37.4	3,260	37.4	3,804	29.9	4,891	29.9
	3 Part Line	2,309	24.9	3,079	24.9	3,849	24.9	4,619	24.9	5,389	19.9	6,928	19.9
	4 Part Line	2,898	18.7	3,864	18.7	4,830	18.7	5,796	18.7	6,762	15.0	8,694	15.0

PLEASE READ THE FOLLOWING CAREFULLY

THE PARTS LIST AND ASSEMBLY DIAGRAMS IN THIS MANUAL ARE A REFERENCE TOOL ONLY. WE DO NOT MAKE ANY REPRESENTATION OR WARRANTY OF ANY KIND TO THE BUYER THAT THEY ARE QUALIFIED TO MAKE ANY REPAIRS OR REPLACE ANY PARTS OF THE PRODUCT. IN FACT, AQUA MARINE SUPPLY/HEFTY HOIST, INC EXPRESSLY STATES THAT ALL REPAIRS SHOULD BE UNDERTAKEN BY CERTIFIED AND LICENSED TECHNICIANS, AND NOT BY THE BUYER. THE BUYER ASSUMES ALL RISK AND LIABILITY ARISING OUT OF HIS OR HER REPAIRS TO THE ORIGINAL PRODUCT OR REPLACEMENT PARTS THERETO, OR ARISING OUT OF HIS OR HER INSTALLATION OF REPLACEMENT PARTS THERETO.

Warranty

The following warranty applies to the components of the models of hoists manufactured by Hefty Hoist, Inc dba Aqua Marine Supply©. This warranty applies to manufacturing defects and/or failures due to design or fabrication. Replacement parts or a new product will be supplied at no charge at the option of Aqua Marine Supply. This does NOT include labor or freight.

- Electrical components including electric motor, wire, switch, GFCI power cords (1 Year)
- E-Gear® gearbox components (2 Years)

This warranty is void if product is improperly installed, maintained or greased. Any changes or alterations to the original design will also void the warranty. The warranty does not cover acts of nature or criminal activity. The warranty is predicated on proof of annual inspection by a qualified technician and a record of inspection must be presented for any warranty claim. The warranty applies only to the original owner and is void if transfer of ownership.

To take advantage of this warranty, the product must be returned to us for evaluation with transportation charges prepaid (unless otherwise directed). Proof of purchase date and an explanation of the complaint must accompany the product otherwise no warranty will be given and the product will only be returned at the cost of the sender.



Troubleshooting

Problem	Possible Causes	Probable Solutions
<p>Electric motor getting hot</p> <p><i>Note: Limit use as much as possible when this occurs. Permanent, irreversible damage could be done to the electric motor</i></p>	<ol style="list-style-type: none"> 1. Low voltage due to insufficient wire size (most common) 2. Improper wiring connections 3. Mechanical binding in lift adding additional stress 	<ol style="list-style-type: none"> 1. Have the voltage checked under load at the motor by a qualified electrical professional. If voltage drop present, check wire size from main panel and ensure sufficient size for the length of the run based on the amp draw of the motor(s) on the E-Gear®. <i>Note: If possible, switch a 115V installation to 230V</i> 2. Ensure the electrical connections are correctly made at the electric motor as well as the control. See HeftyHoist.com for wiring schematics 3. Check lift components according to lift manufacturers instructions for binding including lubricating sheaves and guides.
<p>Electric motor humming in one or both directions</p>	<p>For new installations:</p> <ol style="list-style-type: none"> 1. Improper connections 2. Defective motor or control <p>For existing installations:</p> <ol style="list-style-type: none"> 1. Corrosion 2. Damaged wiring 	<p>For new installations:</p> <ol style="list-style-type: none"> 1. Ensure the electrical connections are correctly made at the electric motor as well as the control (switch or remote control panel). See HeftyHoist.com for wiring schematics 2. Have electrician try to isolate issue is either at the electric motor or control and replace as necessary. <p>For existing installations:</p> <ol style="list-style-type: none"> 1. Have electrician check connections at motor and control for corrosion not allowing full power through. Issue may be internal and faulty item may need replaced. 2. Inspect wiring circuit from control to electric motor for possible damage and repair/replace as necessary.
<p>Electric motor does nothing</p>	<ol style="list-style-type: none"> 1. GFCI has tripped 2. Circuit breaker has tripped 3. Open circuit 	<ol style="list-style-type: none"> 1. Check all GFCI including the one provided by AMS on the power cord if applicable and reset. 2. Check the circuit breaker belonging to the lift and reset if turned off. If breaker continues to trip: <ol style="list-style-type: none"> a. Check if breaker defective b. If breaker working properly, there is a dead short somewhere in the circuit from the breaker to the electric motor. DO NOT use hoist and consult an electrician right away 3. Electrical circuit is open at some point from the breaker to the electric motor. Consult an electrician to isolate the issue
<p>Electric motor is full of water inside</p>	<ol style="list-style-type: none"> 1. Motor submerged during flooding/storm surge 2. Motor was not mounted in correct orientation 3. Weep hole plugs were not removed 	<ol style="list-style-type: none"> 1-3 Replace the motor and ensure it is mounted in correct orientation and that the weep hole drain plugs are removed at the lowest point in the new installation.
<p>E-Gear more noisy in one direction than other</p>	<ol style="list-style-type: none"> 1. Normal operation 2. Bearing placement/overloading/ misalignment 3. Low oil level in high speed chamber 	<ol style="list-style-type: none"> 1. It is normal for the AMS E-Gear® to be slightly noisier in one direction than the other due to gear geometry. 2. Check for misalignment, support bearing placement on lift, binding at sheaves or guides and possibility of lift being overloaded by some margin. 3. Inspect the high speed chamber for lubricant level. The worm-shaft should be at least partially submerged in lubrication.

Problem	Possible Causes	Probably Solutions
Lift stops as soon as boat comes fully out of water	<ol style="list-style-type: none"> 1. Low voltage due to insufficient wire size 2. Mechanical binding in lift adding additional stress 3. Overloaded 	<ol style="list-style-type: none"> 1. Have the voltage checked under load at the motor by a qualified electrical professional. If voltage drop present, check wire size from main panel and ensure sufficient size for the length of the run based on the amp draw of the motor(s) on the E-Gear®. <i>Note: If possible, switch a 115V installation to 230V</i> 2. Check lift components according to lift manufacturers instructions for binding including lubricating sheaves and guides. 3. Ensure that the load is within limits of the E-Gear as well as within the rated capacity of the lift set by the lift manufacturer.
Drive bolt bending or breaking	<ol style="list-style-type: none"> 1. Shock load from cable hanging up temporarily and the lift falling some inches 2. Empty space between the hoist and the drive pipe not filled with a spacer or adapter 3. Bolt was replaced with a stainless steel bolt 	<ol style="list-style-type: none"> 1. Inspect E-Gear® and rest of lift for damages. Highly recommend contacting lift manufacturer or service technician to inspect culprit and/or resulting damages. Replace with new G5 or G8 bolt/nut 2. A spacer or adapter must be fabricated/sourced to fill any empty space between the drive pipe and the opening in the main gear assembly 3. Replace with correct Grade 5 or 8 bolt immediately
Main gear hub cracked/ broken at the drive bolt	<ol style="list-style-type: none"> 1. Shock load from cable hanging up temporarily and the lift falling some inches 2. Drive bolt and nut were overtightened which put pressure on the cast gear hub 	<ol style="list-style-type: none"> 1-2. Replacement of the main gear would be cost-prohibitive and also be a liability concern. As a result, replace the E-Gear® in its entirety.
Bore cap(s) missing or blown off	<ol style="list-style-type: none"> 1. Binding/misalignment/overload causing binding and excessive internal temperature creating a high pressure 2. Overfilled lubrication 	<ol style="list-style-type: none"> 1. Investigate cause of binding, then replace the bore cap 2. Ensure the lubrication levels do not exceed the maximum level



ALL TROUBLESHOOTING, MAINTENANCE, AND REPAIR SHOULD BE COMPLETED ONLY BY A LICENSED PROFESSIONAL AND/OR ELECTRICIAN. FOLLOW ALL WARNING LABELS ON THE HOIST OR SERIOUS INJURY COULD OCCUR