

# AMS FLAT PLATE

MODELS 3000 / 4000 / 6500 / 8500

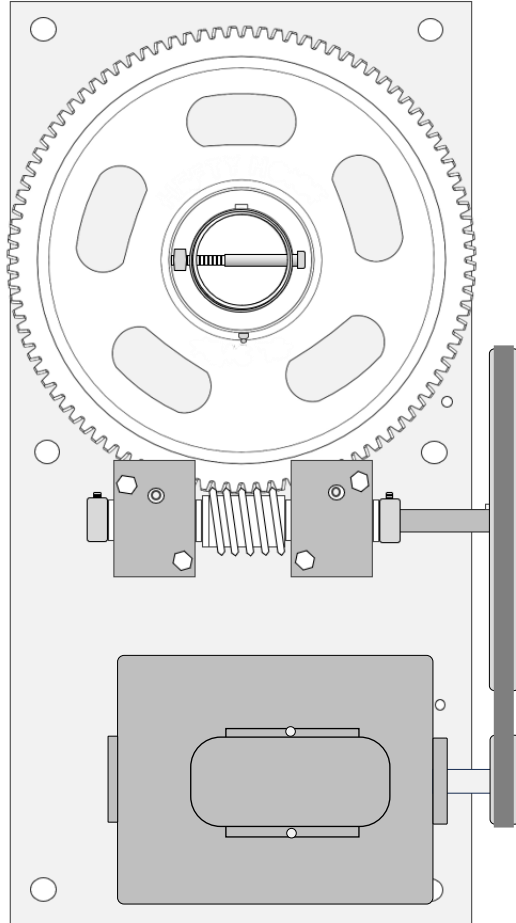

Copyright© 2024 by Aqua Marine Supply/Hefty Hoist, Inc.  
No portion of this manual or any artwork contained herein may be reproduced in any shape or form without the express written consent of Aqua Marine Supply/Hefty Hoist, Inc. Diagrams within this manual may not be drawn proportionally. Due to continuing improvements, actual product may differ slightly from the product described herein.





## **⚠️ WARNING**

**Read this material before using this product. Failure to do so can result in serious injury. SAVE THIS MANUAL**

## Table of Contents

Safety .....	2	Operating/Greasing the Hoist.....	8
Overview .....	3	Specifications .....	8
Mounting Dimensions .....	4	Max Load & Speed Chart .....	9
Technical Information.....	4	Double Pulley Installation (8500).....	10
Installation Information.....	5	Parts List.....	11
Mounting the Motor .....	6	Warranty .....	12
Tensioning the Drive Belt.....	7	Troubleshooting.....	13-14

### WARNING SYMBOLS AND DEFINITIONS

	This is the safety alert symbol. It is used to alert you to potential personal injury hazards. Obey all safety messages that follow this symbol to avoid injury or death
	Indicates a hazardous situation which, if not avoided, will result in death or serious injury
	Indicates a hazardous situation which, if not avoided, Could result in death or serious injury
	Indicates a hazardous situation which, if not avoided, Could result in minor or moderate injury
	Addresses practices not related to personal injury

## IMPORTANT SAFETY INFORMATION

### DANGER

**TO PREVENT SERIOUS INJURY AND DEATH:**

### Basic Safety Information

- Do not lift people or lift loads near people.**  
Falling loads can injure or kill people.  
Do not use as elevator for human use.
- Do not operate the hoist when load is not centered in lift**
- Do not operate hoist with kinked or damaged lift cables**  
Inspect lift cables before every use
- Do not operate hoist if damaged or malfunctioned in any way**
- If servicing or replacing parts, ensure the load is removed and cables are slack**
- Lift should be installed in a location that allows the operator to move and stay clear of the load
- Keep clear of moving parts during operation
- Electrical equipment should only be installed and maintained by a qualified electrician

**Overview & Features**

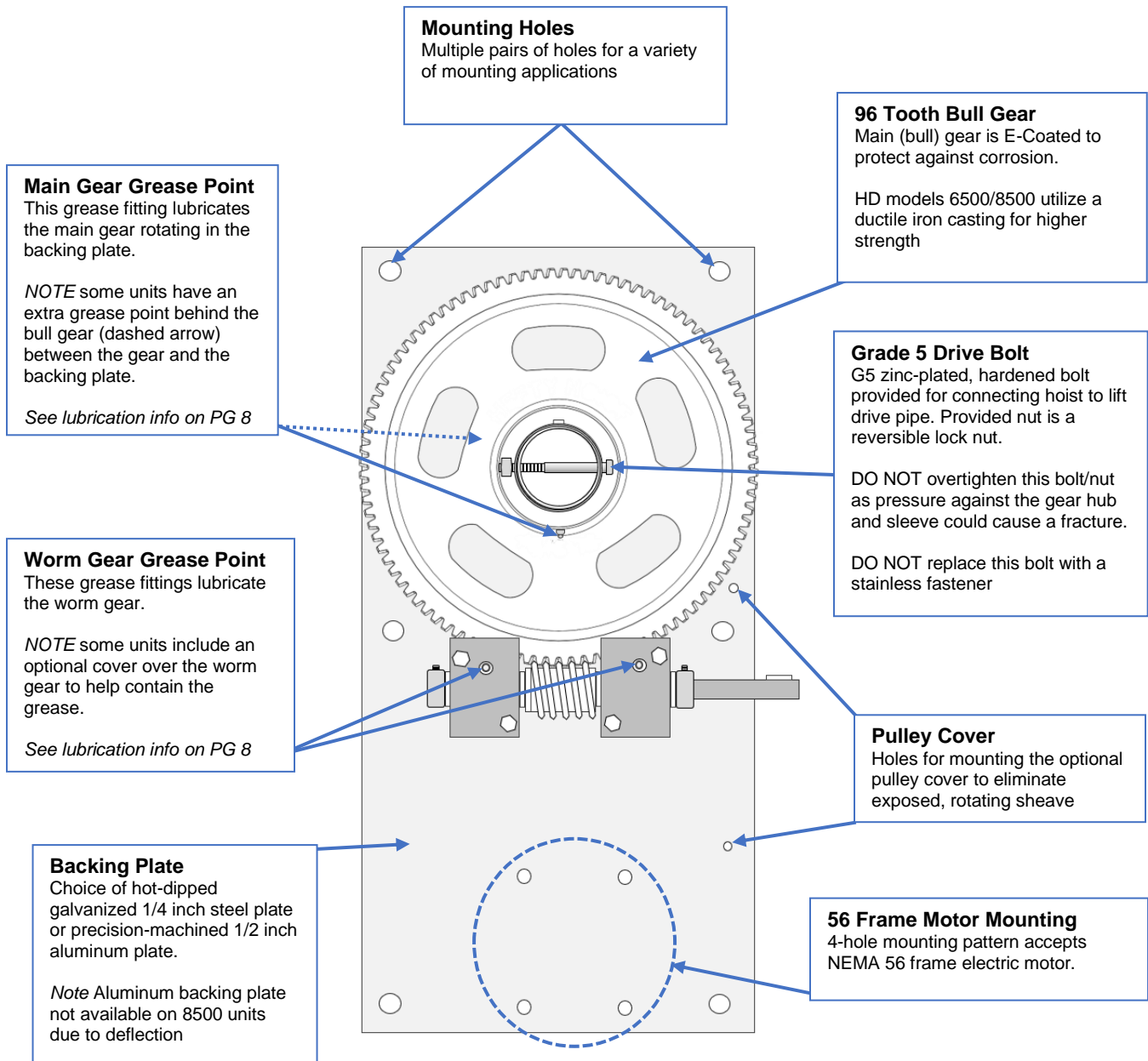

**General Description**

The AMS Flat Plate drive is an electric-powered mechanical hoist intended for use primarily in boat lifts, but also cargo lifts and other specialized applications. The gearing is intentionally designed to be inefficient to hold the rated load without the need for other equipment such as a brake motor. Under normal use and proper maintenance, AMS Flat Plate hoists can last for decades on lifts.

**Mounting Dimensions**

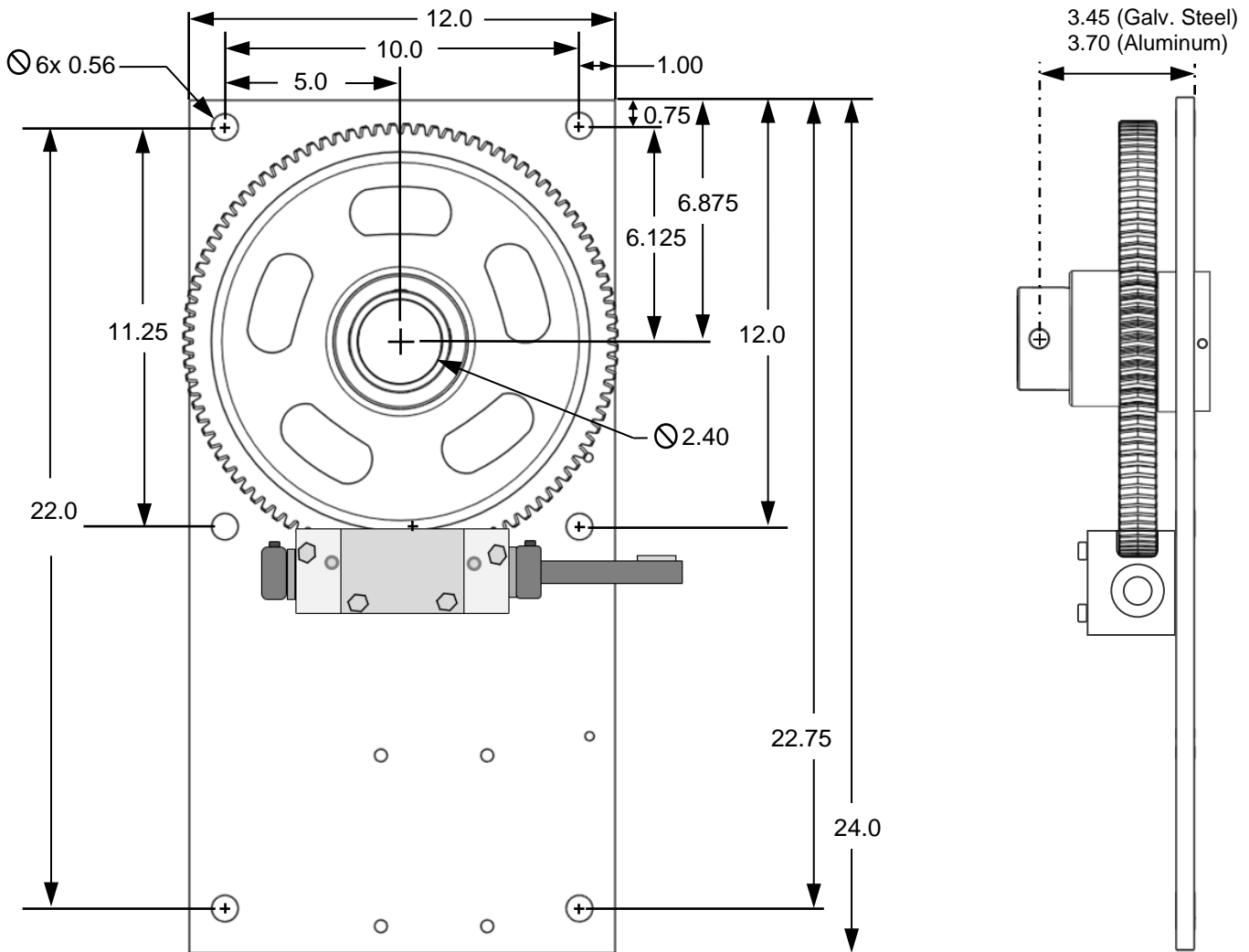

**Technical Information**

**MODELS**

The AMS Flat Plate is available in 4 main models, the 3000, 4000, 6500, and 8500. All four models have identical mounting dimensions and gear ratios. The differences come from the electric motor sizes, gearing material makeup, and the belt/pulley size.

Considering Aqua Marine Supply/Hefty Hoist does not create the entire lift, these model numbers DO NOT refer to the weight capacity of the hoist, but rather the maximum amount of torque (in inch-pounds) that they can handle. The diameter of the winding drum/pipe and the rigging of the lift cables (not supplied by AMS) will greatly affect the

speed and weight capacity of a hoist. The lift manufacturer who utilizes our hoist and sells the lift as a package is the only party that can determine the final weight capacity.

**Standard Flat Plate Configurations**

Model	Plate	Motor HP	Drive Pulley	Belt
3000	RD	3/4	10"	AX34
4000	RD	1	10"	AX34
6500	HD	1 HD	10" Steel	AX34
8500	HD	1-1/2	11" Steel Double	AX37 (2)

### BACKING PLATE & BELT ORIENTATION

There are currently two options for backing plates on the AMS Flat Plate hoist: 1/4 inch galvanized steel and 1/2 inch aluminum. All models can be purchased with either material except for the 8500 (galvanized only). There is also an option to have the belt/pulley on either the right or left side of the hoist, however the standard is the right-hand orientation. If a left-hand version is needed, a special backing plate with holes in mirrored locations must be used otherwise the electric motor will be out of position.

### SPEED & TORQUE

Speed and torque are an inverse relationship, and anything done to speed the hoist up will decrease its output torque. The Flat Plate uses a belt and two different sized pulleys as the first reduction stage. In most cases, the pulley on the electric motor is 2 inches in diameter. The pulley on the input shaft of the Flat Plate hoist is normally 10-11 inches but can be sized down to speed the hoist up. However, downsizing the drive pulley will reduce the output torque by the same margin. The pulley should never be downsized by an end user unless authorized by the lift manufacturer.

## Installation Information

### NOTICE

### CAUTION

**Alignment:** It is important that the Flat Plate hoist be mounted so that the winding pipe is concentric and in line with the opening in the main gear assembly. Misalignment at this point can cause binding, wear, and noise and will void the warranty.

**Orientation:** The Flat Plate should be mounted vertically with the motor at the lowest point but can be mounted horizontally if necessary (usually for clearance in boat house applications).

**Bearing Placement:** As with all AMS drives, it is important that the drive shaft or winding pipe being used on the lift is supported properly with bearings. AMS drives are made to turn the pipe and are not to be load bearing. Therefore, it is important that a support bearing be mounted as close as possible to the hoist mount.

**Mounting Holes:** The backing plate should be fastened to the lift piling, beam, or structural joist to prevent the hoist from rotating under operation. It is recommended that only one pair of mounting holes is utilized. This will allow the hoist to flex slightly under load to prevent binding. Using multiple pairs of mounting holes may create too rigid of a mount and place undue stress under certain events.

**Drive Bolt & Nut:** The provided drive bolt is a grade 5, zinc-plated, casehardened 1/2 inch bolt with yield and breaking strength far superior to the maximum load rating

of the hoist. DO NOT replace this bolt with a stainless steel bolt for any reason. The provided nut is a reversible lock nut which can be installed in either direction and will lock in position similar to a nylon lock nut. This nut should NOT be tightened all the way against the gear sleeve as pressure against it could fracture the sleeve. The nut is only good for one use and should be replaced if needed to be removed for any reason.

**Winding/Drive Pipe:** The Flat Plate hoist is designed to mount to a 2 inch pipe (2.375 inch outside diameter). If a 1-1/2 inch pipe is being used, then a spacer or adapter must be added (not provided by AMS) to take up the empty space.

### ⚠WARNING

**Failure to fill this empty space with a spacer can cause the provided drive bolt to bend or fail which could lead to catastrophic failure.**

## Mounting the Electric Motor

### **⚠ WARNING**

**TO PREVENT SERIOUS INJURY, ENSURE THE ELECTRICAL CIRCUIT IS SWITCHED OFF BEFORE PROCEEDING**

1. Position the mounting foot of the electric motor onto the Flat Plate hoist backing plate.
2. Using the (4) provided 5/16" carriage bolts, washers and nuts, loosely secure as shown in Figure 6a to hold the motor in position.
3. Install the Drive Belt around both pulleys with the cogs facing inward
4. Pull the motor downward to remove the slack from the Drive Belt.
5. Ensuring that the motor is straight across the backing plate and the motor pulley and drive pulley are aligned (see Figure 6b), tighten two of the mounting nuts to keep the motor in place.
6. See **Page 7** for tensioning the Drive Belt further

**Figure 6a**

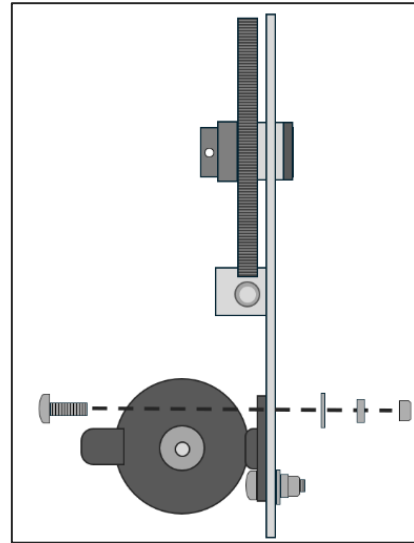

**Figure 6b**

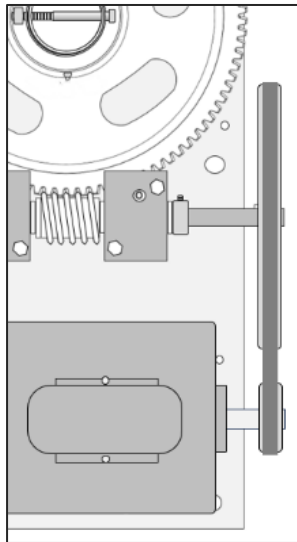

Straight AND aligned

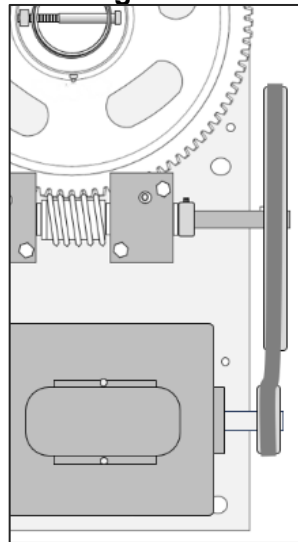

Straight, NOT aligned

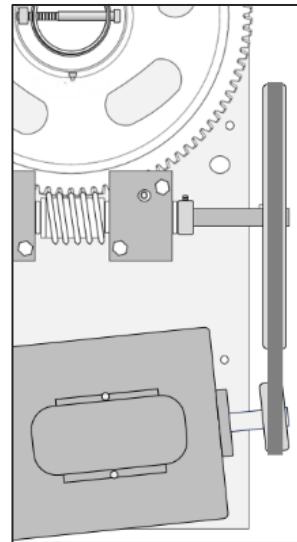

Not straight OR aligned



## Tensioning the Drive Belt

---

### **⚠ WARNING**

**TO PREVENT SERIOUS INJURY, ENSURE THE ELECTRICAL CIRCUIT IS SWITCHED OFF BEFORE PROCEEDING**

1. Attach motor and Drive Belt according to steps on **Page 6**.
2. Make a mark on the Backing Plate with a fine marker around one corner of the motor mounting foot to reference the current location.
3. Loosen the mounting hardware slightly until the Motor can be moved.
4. Remove the Drive Belt temporarily.
5. Reposition the Motor to the mark made in Step 2 and then move the Motor straight down approximately 1/4 inch and retighten at least two of the nuts. Be sure to maintain the alignment of the pulleys and that the Motor is still straight across the Backing Plate.
6. Install the Drive Belt fully around the Motor Pulley and install as much of the Drive Belt into the larger Drive Pulley as possible.
7. Rotate the Drive Pulley by hand until the Drive Belt fully positions into the groove.

*Note: If it requires too much effort to execute step 7, Go back to Step 5 and position the motor closer to the original mark.*

## Electric Motor Connections

---

The provided electric motor from Aqua Marine Supply/Hefty Hoist, Inc is a 115/230V, single phase, reversible motor that should only be installed by a qualified electrician. The electrical circuit should be GFCI protected and should contain the proper size wiring to ensure full voltage to the motor on the hoist. Failure to supply the correct and full electrical voltage to the motor or failing to make the proper connections will permanently damage the motor and is not covered by warranty.

For electric motors that were not wired to controls from factory, wiring schematics can be found at [www.HeftyHoist.com/wiring-diagrams](http://www.HeftyHoist.com/wiring-diagrams). Please do not contact us with questions about compatibility with non-AMS equipment as we will not be able to assist.

## Before Operating Hoist

---

1. Familiarize yourself with all operating controls of the hoist and with the operation(s) of the manufacturer's lift. Also familiarize yourself with the instructions, including the warning(s) on the hoist and lift and with the safety information within this manual. Read all information provided by the lift manufacturer regarding your specific lift.
2. **TO PREVENT SERIOUS INJURY FROM LIFT FAILURE:**  
**Do not use damaged equipment. If repairs are necessary or any defect known, have the issues corrected before use.**
3. Inspect the Hoist and other lift components thoroughly before use including the need for the addition of grease (see Greasing the Hoist on Page 8).

## Operating the Hoist

### For AMS Reversing Switch installations:

Rotate the switch handle to the desired lifting direction (UP or DOWN). See Figure 8a

**NOTE:** A **Momentary** style switch will require the user to hold the handle in the desired operating position and if released, the handle should return to the OFF position automatically. A **Maintaining** style switch will allow the switch handle to maintain the position selected throughout operation and the handle needs to be rotated back by the user to the OFF position when finished.

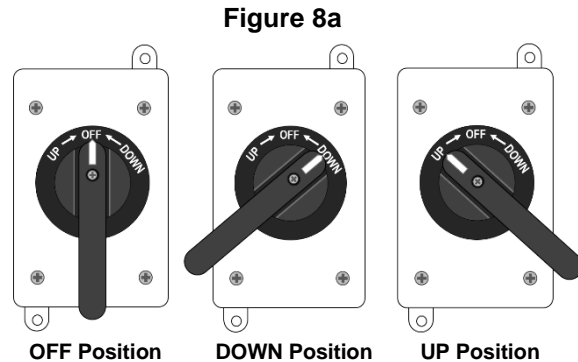

### For Remote Control installations:

Follow directions provided by the Remote Control manufacturer for proper operation.

## Greasing the Flat Plate Hoist

There are multiple grease fittings on the Flat Plate Hoist that require periodic lubrication. See the diagram on **Page 3** for locations. There is at least one fitting for the main bull gear and fittings on each of the guide blocks surrounding the worm gear. The amount of time between adding grease to the hoist heavily depends on the frequency of use and the environment in which it is installed. Under typical residential use in a Boat Lift application, we recommend the Flat Plate be inspected for grease at least once during the boating season. It is highly advisable to inspect at the beginning and end of the season as well. Failure to maintain adequate grease will void the warranty.

### Grease Type

The AMS Flat Plate hoist requires a high-temp moly grease. The hoists are factory-lubricated with *Mobil Centaur Moly II*.

## Specifications

Model	3000	4000	6500	8500
Torque Rating	3,000 in-lb	4,000 in-lb	6,500 in-lb	8,500 in-lb
Backing Plate	1/2" Aluminum or 1/4" Galvanized Steel			1/4" Galvanized Steel
Motor HP	3/4	1	1 HD	1-1/2
Motor Amps (115/230)	12.2 / 6.1	12.2 / 6.1	13.6 / 6.8	22.0 / 11.0
Rated Motor RPM	1725			
Standard Gear Ratio	480:1			537:1
Standard Output RPM	3.59			3.21
Standard Belt Size	AX34			AX37 (x2)
Grease Type	High-temp Moly			
Straight-pull maximum load (2.375 OD pipe) see Page 8	2,526 lb	3,368 lb	5,474 lb	7,158 lb



**Max Load & Lift Speed Chart**

The following chart can be used to determine the maximum load a particular hoist can lift based on the winding pipe and cable configuration. The chart only accommodates for lifts with one **standard** hoist; if multiple hoists are used on the same lift, then multiply the Max Load value in the chart by the number of Flat Plate Hoists on the lift.

\*\*"Winding Pipe" refers to the surface where the cable actually winds up. If a sleeve, winder, or spool is used over the nominal drive pipe, use the OD of that item and see corresponding line in chart (**Figure 9a** below). The chart assumes neatly wrapped lift cable and does not accommodate for overlap which will affect speed and max load.

\*\*See **figure 9b** for Cable Compounding information

Winding Pipe*	Lift Cable Compounding**	3000 Flat Plate		4000 Flat Plate		6500 Flat Plate		8500 Flat Plate	
		Max Load per Hoist (lb)	Vertical Speed (in/min)	Max Load per Hoist (lb)	Vertical Speed (in/min)	Max Load per Hoist (lb)	Vertical Speed (in/min)	Max Load per Hoist (lb)	Vertical Speed (in/min)
1.5" Pipe (1.9" OD)	Straight Pull	3,000	21.5	4,000	21.5	6,500	21.5	8,500	19.2
	2 Part Line	5,684	10.7	7,579	10.7	12,316	10.7	16,105	9.6
	3 Part Line	8,053	7.2	10,737	7.2	17,447	7.2	22,816	6.4
	4 Part Line	10,105	5.4	13,474	5.4	21,895	5.4	28,632	4.8
2" Pipe (2.38" OD)	Straight Pull	2,526	26.8	3,368	26.8	5,474	26.8	7,158	23.9
	2 Part Line	4,547	13.4	6,063	13.4	9,853	13.4	12,884	12.0
	3 Part Line	6,442	8.9	8,589	8.9	13,958	8.9	18,253	8.0
	4 Part Line	8,084	6.7	10,779	6.7	17,516	6.7	22,905	6.0
2.5" Pipe (2.88" OD)	Straight Pull	2,087	32.5	2,783	32.5	4,522	32.5	5,913	29.0
	2 Part Line	3,757	16.2	5,009	16.2	8,139	16.2	10,643	14.5
	3 Part Line	5,322	10.8	7,096	10.8	11,530	10.8	15,078	9.7
	4 Part Line	6,678	8.1	8,904	8.1	14,470	8.1	18,922	7.2
3" Pipe (3.5" OD)	Straight Pull	1,714	39.5	2,286	39.5	3,714	39.5	4,857	35.3
	2 Part Line	3,086	19.8	4,114	19.8	6,686	19.8	8,743	17.6
	3 Part Line	4,371	13.2	5,829	13.2	9,471	13.2	12,386	11.8
	4 Part Line	5,486	9.9	7,314	9.9	11,886	9.9	15,543	8.8
3.5" Pipe (4" OD)	Straight Pull	1,500	45.2	2,000	45.2	3,250	45.2	4,250	40.3
	2 Part Line	2,700	22.6	3,600	22.6	5,850	22.6	7,650	20.2
	3 Part Line	3,825	15.1	5,100	15.1	8,288	15.1	10,838	13.4
	4 Part Line	4,800	11.3	6,400	11.3	10,400	11.3	13,600	10.1
4" Pipe (4.5" OD)	Straight Pull	1,333	50.8	1,778	50.8	2,889	50.8	3,778	45.4
	2 Part Line	2,400	25.4	3,200	25.4	5,200	25.4	6,800	22.7
	3 Part Line	3,400	16.9	4,533	16.9	7,367	16.9	9,633	15.1
	4 Part Line	4,267	12.7	5,689	12.7	9,244	12.7	12,089	11.3
5" Pipe (5.56" OD)	Straight Pull	1,079	62.8	1,438	62.8	2,337	62.8	3,056	56.1
	2 Part Line	1,941	31.4	2,589	31.4	4,206	31.4	5,501	28.0
	3 Part Line	2,750	20.9	3,667	20.9	5,959	20.9	7,793	18.7
	4 Part Line	3,451	15.7	4,602	15.7	7,478	15.7	9,779	14.0
6" Pipe (6.63" OD)	Straight Pull	906	74.8	1,208	74.8	1,962	74.8	2,566	66.8
	2 Part Line	1,630	37.4	2,174	37.4	3,532	37.4	4,619	33.4
	3 Part Line	2,309	24.9	3,079	24.9	5,004	24.9	6,543	22.3
	4 Part Line	2,898	18.7	3,864	18.7	6,279	18.7	8,211	16.7

**Figure 9a**

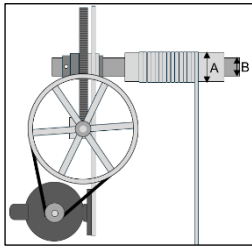

In the above example, dimension "A" would be the value used in the load chart, NOT "B"

**Figure 9b**

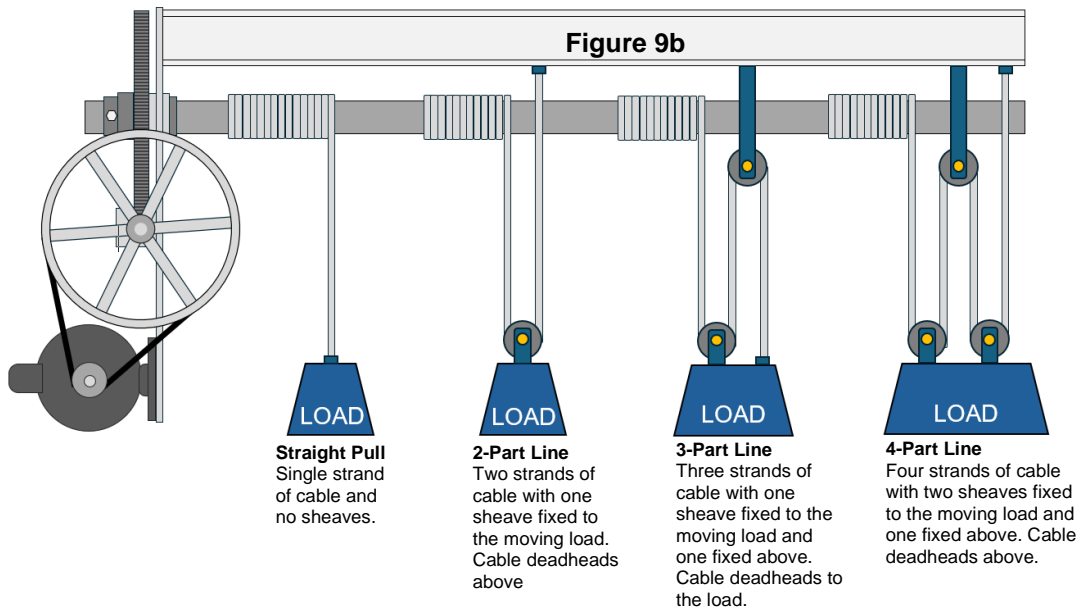

Double Pulley Installation (8500 models only)

**DOUBLE PULLEY INSTALLATION INSTRUCTIONS**

The double-grooved drive pulley is the standard pulley on the model 8500. It is a 2-piece assembly consisting of the actual sheave (A) and a mandrel bushing (B). The bushing comes with (2) bolts and washers (C)

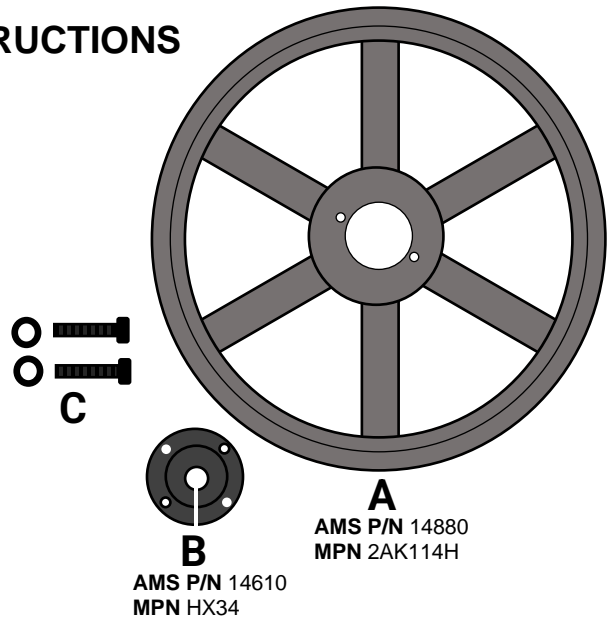
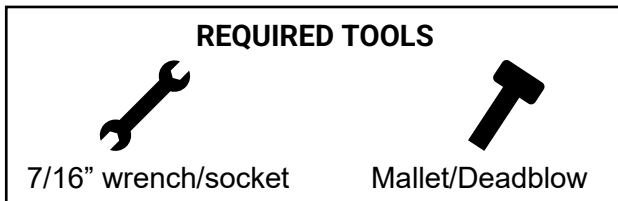

**STEP 1**

Insert the mandrel bushing (B) gently into the bore of the main sheave (A). The bushing is tapered and will not slide all the way in.

*NOTE: Be sure the lettering on the hub of the sheave is facing towards the mandrel before inserting.*

**STEP 2**

Line up the non-threaded holes in the mandrel bushing with the threaded holes in the sheave and insert the provided bolts & washers. Only start the bolts, DO NOT tighten yet.

*NOTE: The threaded holes in the bushing are only for removing the bushing later on if necessary*



**STEP 3**

Slide the assembly onto the worm gear shaft of the Flat Plate Hoist, lightly tapping with a rubber mallet if necessary. Make sure the woodruff key is installed on the shaft and line the key up with the keyway in the bushing. Slide the assembly as close the backing plate as possible without touching. The shaft will not be all the way through the assembly!



**STEP 4**

Using a 7/16" wrench or socket, tighten the bolts alternately until they are snug, DO NOT overtighten.

*NOTE: There will be a gap between the flange on the bushing and the hub of the sheave (this is normal). The end of the shaft will only be partway through the sheave & bushing assembly (also normal).*

**REMOVING THE DOUBLE PULLEY**

Remove the bolts completely and reinsert into the threaded holes of the bushing and re-tighten. This will force the bushing out of the main sheave.

**Parts List and Diagrams**

Part	Description
1	<b>Backing Plate -2 Options-</b> 1/4" Galvanized Steel 1/2" Aluminum
2	<b>Bull Gear, 96 Tooth, with Sleeve &amp; Lock Collar -2 Options-</b> RD Gray Iron (3000 / 4000 models) HD Ductile Iron (6500 / 8500 models)
3	<b>Worm Gear Assembly</b> Bronze Worm Gear, 3/4" keyed shaft, (2) aluminum guide blocks with bronze bushings, (2) 3/4" Lock Collars
4	<b>Drive Bolt</b> 1/2-13 x 3-1/2 inch grade 5, zinc-plated bolt 1/2-13 zinc-plated reversible lock nut
5	<b>Woodruff Key</b> #16 Woodruff (half-moon) key
6	<b>Grease Cup (optional)</b> Aluminum cover for worm gear

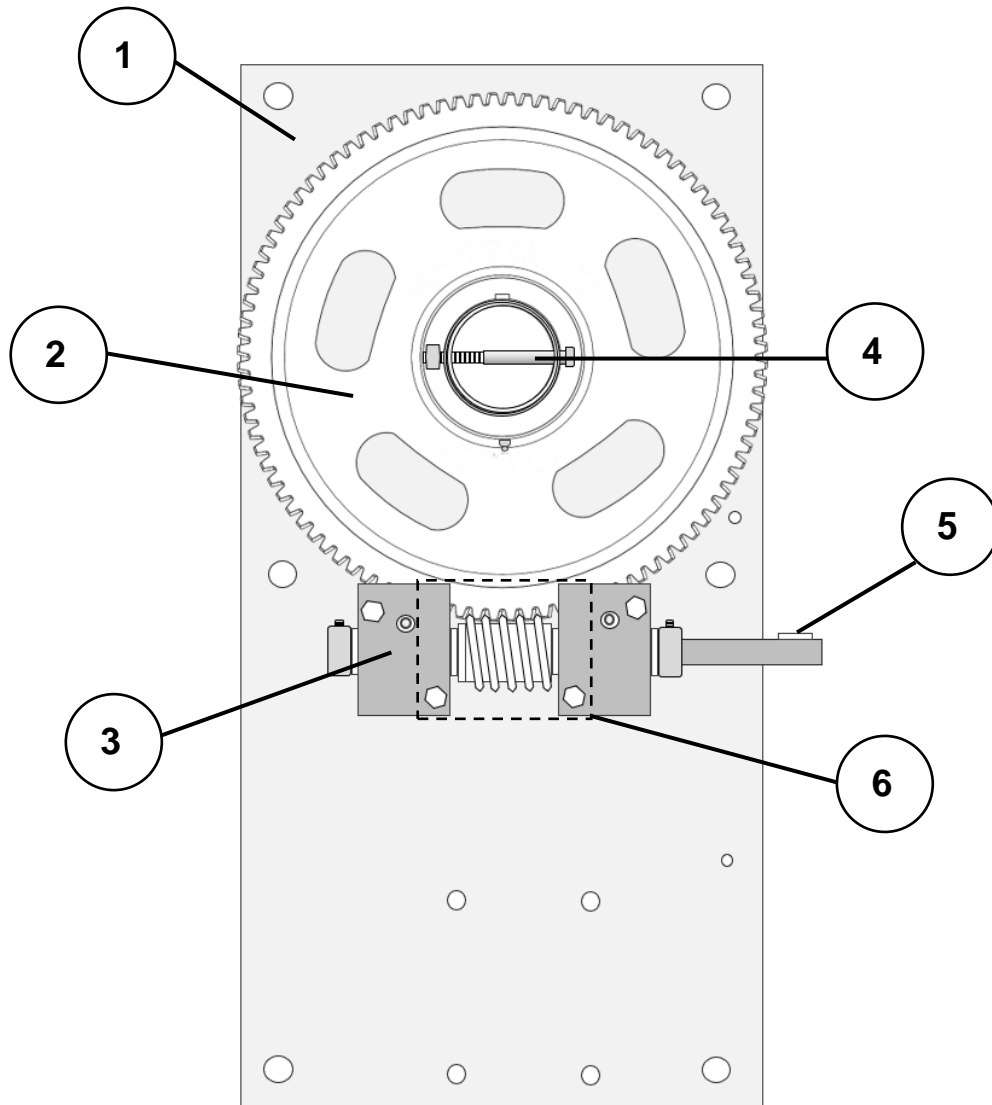

## PLEASE READ THE FOLLOWING CAREFULLY

---

THE PARTS LIST AND ASSEMBLY DIAGRAM IN THIS MANUAL ARE A REFERENCE TOOL ONLY. WE DO NOT MAKE ANY REPRESENTATION OR WARRANTY OF ANY KIND TO THE BUYER THAT THEY ARE QUALIFIED TO MAKE ANY REPAIRS OR REPLACE ANY PARTS OF THE PRODUCT. IN FACT, AQUA MARINE SUPPLY/HEFTY HOIST, INC EXPRESSLY STATES THAT ALL REPAIRS SHOULD BE UNDERTAKEN BY CERTIFIED AND LICENSED TECHNICIANS, AND NOT BY THE BUYER. THE BUYER ASSUMES ALL RISK AND LIABILITY ARISING OUT OF HIS OR HER REPAIRS TO THE ORIGINAL PRODUCT OR REPLACEMENT PARTS THERETO, OR ARISING OUT OF HIS OR HER INSTALLATION OF REPLACEMENT PARTS THERETO.

**NOTE: Some parts listed above may not be available for purchase for liability reasons and a complete gear plate assembly would need to be purchased**

### Warranty

The following warranty applies to the components of the models of hoists manufactured by Hefty Hoist, Inc dba Aqua Marine Supply©. This warranty applies to manufacturing defects and/or failures due to design or fabrication. Replacement parts or a new product will be supplied at no charge at the option of Aqua Marine Supply. This does NOT include labor or freight.

- Electrical Components including electric motor, wire, switch, GFCI power cords, etc (1 Year)
- Flat Plate Hoist components (5 Years)

This warranty is void if product is improperly installed, maintained or greased. Any changes or alterations to the original design will also void the warranty. The warranty does not cover acts of nature or criminal activity. The warranty is predicated on proof of annual inspection by a qualified technician and a record of inspection must be presented for any warranty claim. The warranty applies only to the original owner and is void if transfer of ownership.

To take advantage of this warranty, the product must be returned to us for evaluation with transportation charges prepaid (unless otherwise directed). Proof of purchase date and an explanation of the complaint must accompany the product otherwise no warranty will be given and the product will only be returned at the cost of the sender.



## Troubleshooting

Problem	Possible Causes	Probable Solutions
Drive belt slipping	<ol style="list-style-type: none"> <li>1. Belt needs tensioned more</li> <li>2. Grease or debris on belt or in pulley groove</li> <li>3. Mechanical binding in lift adding additional stress</li> <li>4. Hoist is overloaded</li> </ol>	<ol style="list-style-type: none"> <li>1. Follow steps on Page 7 to further tension the belt. Also ensure belt size is correct</li> <li>2. Clean belt and pulley grooves or replace if necessary</li> <li>3. Check lift components according to lift manufacturers instructions for binding including lubricating sheaves and guides.</li> <li>4. Make sure your boat or load is within the rated capacity of the lift/hoist</li> </ol>
Drive belt flipping	<ol style="list-style-type: none"> <li>1. Pulleys misaligned</li> <li>2. Defective/damaged drive belt</li> </ol>	<ol style="list-style-type: none"> <li>1. Check pulley alignment and ensure the electric motor is mounted straight across the backing plate</li> <li>2. Replace belt</li> </ol>
Electric motor getting hot  <i>Note: Limit use as much as possible when this occurs. Permanent, irreversible damage could be done to the electric motor</i>	<ol style="list-style-type: none"> <li>1. Low voltage due to insufficient wire size (most common)</li> <li>2. Improper wiring connections</li> <li>3. Mechanical binding in lift adding additional stress</li> </ol>	<ol style="list-style-type: none"> <li>1. Have the voltage checked under load at the motor by a qualified electrical professional. If voltage drop present, check wire size from main panel and ensure sufficient size for the length of the run based on the amp draw of the motor(s) on the Flat Plate Hoist. <i>Note: If possible, switch a 115V installation to 230V</i></li> <li>2. Ensure the electrical connections are correctly made at the electric motor as well as the control. See HeftyHoist.com for wiring schematics</li> <li>3. Check lift components according to lift manufacturers instructions for binding including lubricating sheaves and guides.</li> </ol>
Electric motor humming in one or both directions	For new installations: <ol style="list-style-type: none"> <li>1. Improper connections</li> <li>2. Defective motor or control</li> </ol> For existing installations: <ol style="list-style-type: none"> <li>1. Corrosion</li> <li>2. Damaged wiring</li> </ol>	For new installations: <ol style="list-style-type: none"> <li>1. Ensure the electrical connections are correctly made at the electric motor as well as the control (switch or remote control panel). See HeftyHoist.com for wiring schematics</li> <li>2. Have electrician try to isolate issue is either at the electric motor or control and replace as necessary.</li> </ol> For existing installations: <ol style="list-style-type: none"> <li>1. Have electrician check connections at motor and control for corrosion not allowing full power through. Issue may be internal and faulty item may need replaced.</li> <li>2. Inspect wiring circuit from control to electric motor for possible damage and repair/replace as necessary.</li> </ol>
Electric motor does nothing	<ol style="list-style-type: none"> <li>1. GFCI has tripped</li> <li>2. Circuit breaker has tripped</li> <li>3. Open circuit</li> </ol>	<ol style="list-style-type: none"> <li>1. Check all GFCI including the one provided by AMS on the power cord if applicable and reset.</li> <li>2. Check the circuit breaker belonging to the lift and reset if turned off. If breaker continues to trip:               <ol style="list-style-type: none"> <li>a. Check if breaker defective</li> <li>b. If breaker working properly, there is a dead short somewhere in the circuit from the breaker to the electric motor. DO NOT use hoist and consult an electrician right away</li> </ol> </li> <li>3. Electrical circuit is open at some point from the breaker to the electric motor. Consult an electrician to isolate the issue</li> </ol>
Electric motor is full of water inside	<ol style="list-style-type: none"> <li>1. Motor submerged during flooding/storm surge</li> <li>2. Motor was not mounted in correct orientation</li> <li>3. Weep hole plugs were not removed</li> </ol>	<ol style="list-style-type: none"> <li>1-3 Replace the motor and ensure it is mounted in correct orientation and that the weep hole drain plugs are removed at the lowest point in the new installation.</li> </ol>

<b>Problem</b>	<b>Possible Causes</b>	<b>Probable Solutions</b>
Hoist squealing in down direction or both directions	<ol style="list-style-type: none"> <li>1. Lack of grease</li> <li>2. Support bearing placement</li> <li>3. Clearance issue with main gear rubbing the guide blocks.</li> <li>4. Overload/misalignment</li> </ol>	<ol style="list-style-type: none"> <li>1. Inspect grease on the worm gear as well as the sleeve in the main gear and add if necessary</li> <li>2. Make sure there are drive pipe support bearings as close to the Flat Plate as possible</li> <li>3. Remove the hoist and try to reposition the main gear by moving the back lock collar and retightening the set screws. If noise persists, replace the Flat Plate hoist.</li> <li>4. Check for misalignment of the drive pipe to the hoist and/or adhere to weight limits set forth by the lift manufacturer.</li> </ol>
Worm gear getting hot/smoking	<ol style="list-style-type: none"> <li>1. Major binding due to misalignment or overloading</li> <li>2. Support bearing placement</li> </ol>	<ol style="list-style-type: none"> <li>1. Check for misalignment of the drive pipe to the hoist and/or adhere to weight limits set forth by the lift manufacturer.</li> <li>2. Make sure there are drive pipe support bearings as close to the Flat Plate as possible</li> </ol>
Bull gear cracked or missing teeth	<ol style="list-style-type: none"> <li>1. Shock load has caused catastrophic damage</li> </ol>	<ol style="list-style-type: none"> <li>1. Replace the Flat Plate hoist</li> </ol>
Lift stops as soon as boat comes fully out of water	<ol style="list-style-type: none"> <li>1. Low voltage due to insufficient wire size</li> <li>2. Mechanical binding in lift adding additional stress</li> </ol>	<ol style="list-style-type: none"> <li>1. Have the voltage checked under load at the motor by a qualified electrical professional. If voltage drop present, check wire size from main panel and ensure sufficient size for the length of the run based on the amp draw of the motor(s) on the Flat Plate Hoist. <i>Note: If possible, switch a 115V installation to 230V</i></li> <li>2. Check lift components according to lift manufacturers instructions for binding including lubricating sheaves and guides.</li> </ol>
Hoist grease fittings not accepting grease	<ol style="list-style-type: none"> <li>1. Broken grease fitting</li> <li>2. Dried grease inside the main gear sleeve preventing new grease from entering due to lack of maintenance</li> </ol>	<ol style="list-style-type: none"> <li>1. Try to replace the 1/4 inch drive zerk fitting or replace the hoist completely</li> <li>2. Try to clean out the channel in the sleeve with brake cleaner or some other solvent and try to grease again. OR send hoist back to us for repair. OR replace the hoist</li> </ol>
Drive bolt bending or breaking	<ol style="list-style-type: none"> <li>1. Shock load from cable hanging up and going slack and then the lift falling some amount</li> <li>2. Empty space between the hoist and the drive pipe not filled with a spacer or adapter</li> <li>3. Bolt was replaced with a stainless steel bolt</li> </ol>	<ol style="list-style-type: none"> <li>1. Inspect hoist and rest of lift for damages. Highly recommend contacting lift manufacturer or service technician to inspect culprit and/or resulting damages. Replace with new G5 or G8 bolt/nut</li> <li>2. A spacer or adapter must be fabricated/sourced to fill any empty space between the drive pipe and the opening in the main gear assembly</li> <li>3. Replace with correct G5 or G8 bolt immediately</li> </ol>



**ALL TROUBLESHOOTING, MAINTENANCE, AND REPAIR SHOULD BE COMPLETED ONLY BY A LICENSED PROFESSIONAL AND/OR ELECTRICIAN. FOLLOW ALL WARNING LABELS ON THE HOIST OR SERIOUS INJURY COULD OCCUR**